



**CHA SHAFT MOUNTED
SPEED REDUCERS**



INTRODUCTION

CHA shaft mounted gear units have been conceived to be mainly used for belt conveyors, because of backstop system mounting possibility they can be used on inclined planes assuring the system irreversibility.

The reducers are manufactured with GG20 painted cast iron cases and grinded gears 21NiCrMo2 material.

PRODUCT FEATURES

- High efficiency
- Low noise
- Easy mounting
- Backstop mounting possibility

CHA gearboxes are manufactured in 8 sizes. Other ratios available on request.



POWER P

$$P_1 \cdot \eta = P_2$$

P_1 = Input power

P_2 = Output power

η = Transmission efficiency

ROTATION SPEED n

n_1 = Input speed

n_2 = Output speed

An output speed ≤ 1400 rpm is suggested so as to optimize the working condition and extend the service life.

TRANSMISSION RATIO i

$$i = \frac{n_1}{n_2}$$

TORQUE M

$$M_2 = \frac{9550 \cdot P_1 \cdot \eta}{n_2} \quad [\text{Nm}]$$

$$M_2 \geq M_{2n} \cdot f_s \quad [\text{Nm}]$$

M_2 = Output torque

M_{2n} = Rated output torque

P_1 = Input power

η = Transmission efficiency

f_s = Service factor



SERVICE FACTOR F_s

The service factor mainly depends on three parameters:

- type to load: U - M - H
- run time: h/day
- start-up frequency: na/h

U = uniform
M = moderate
H = heavy
na/h = starts/hour

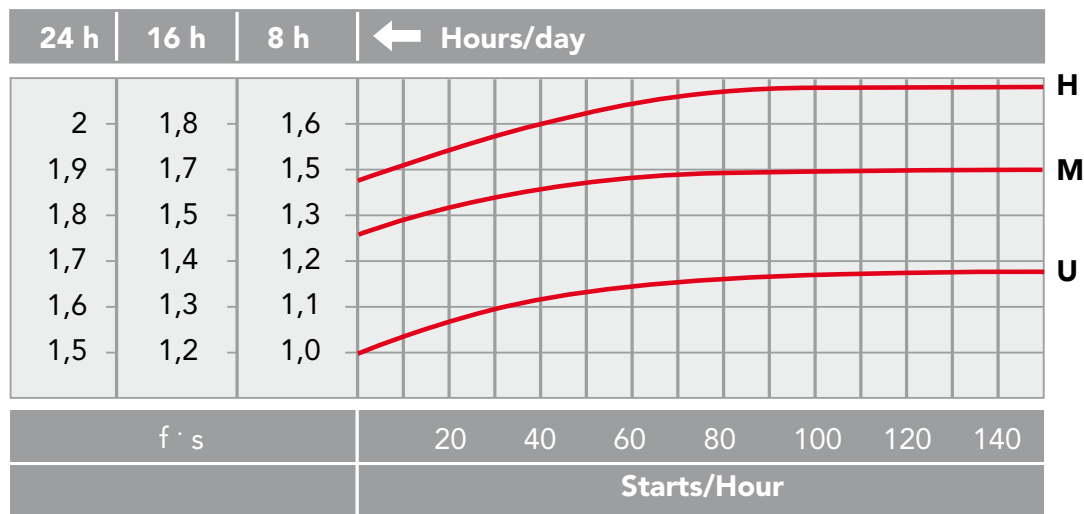

LOAD TYPE/APPLICATION

- U** Conveyor belts for light weights - centrifugal pumps - lifts - bottling machines
- M** Conveyor belts for heavy weights - packing machines - wood working machines - gear pumps
- H** Mixers - bucket elevators - tooling machines - machinery for bricks - vibrators



RADIAL LOADS F_R

The radial loads is proportional to the requested torque and inversely proportional to the transmission member diameter following this formula.

$$F_R = \frac{2000 \cdot T \cdot T.e.f.}{D} \quad [N]$$

- F_R = Radial load
- T = Nm (Torque)
- T.e.f. = Transmission element factor
- T.e.f. = 1,15 gear
- = 1,4 chain sprocket
- = 1,75 v-pulley
- = 2,5 flat-pulley
- D = Transmission element diameter
- R_{n1} = Radial load allowed on input shaft

Relationship between radial load F_R e R_{n1} must be provided according to following representation.

$$F_R \leq F_{n1}$$



BACKSTOP DEVICE

125

On request it is possible to have, with the exception of CHA 30, the backstop device. The direction of free rotation must be specified when the order is placed.

ROTATION





SERVICE FACTOR F_s

The service factor mainly depends on three parameters:

- type to load: U - M - H
- run time: h/day
- start-up frequency: na/h

U = uniform
M = moderate
H = heavy
na/h = starts/hour

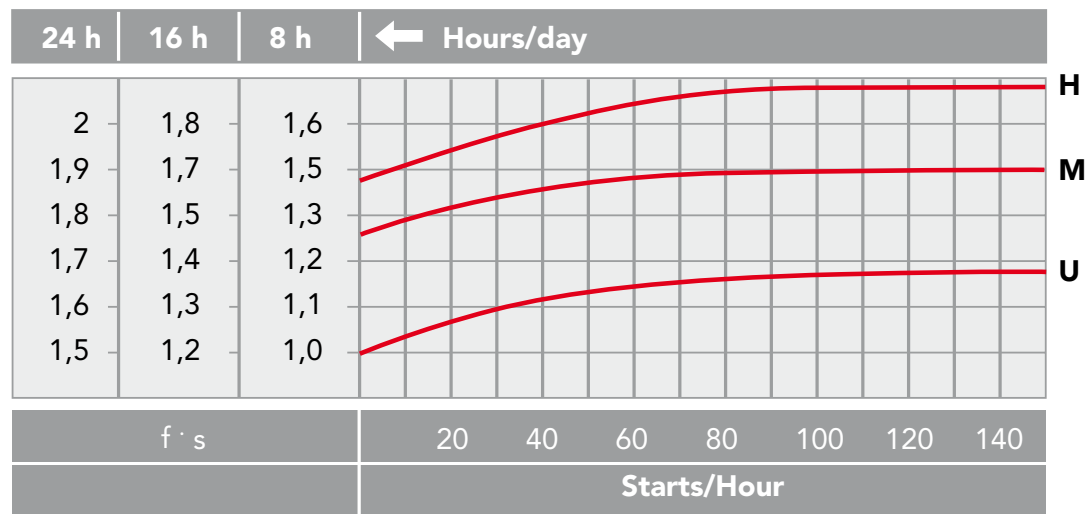

4

LOAD TYPE - APPLICATION

- U** Conveyor belts for light weights - centrifugal pumps - lifts - bottling machines
- M** Conveyor belts for heavy weights - packing machines - wood working machines - gear pumps
- H** Mixers - bucket elevators - tooling machines - machinery for bricks - vibrators



V6/B8 MOUNTING POSITION

When the worm gearboxes mounting position is V6 or B8, with continuous work or input speed >1400 p.p.m, it is necessary to call our technical service.

2D and 3D drawings available on the web site www.chiaravalli.com
 Quantity, availability and prices with Chiaravalli B2B



Gears of CHA gear unit series run at oil bath and lubrication could be provided with splashing. Applicable plug position and oil quantity are given at tables according to variable mounting positions. Suitable checking of oil level must always be according to center of oil-level plug or with dipstick. Sometimes, there are possibility difference between oil-level and oil quantity which is given at table.

LUBRICATION (Litres)							
CHA 30	CHA 35/2	CHA 40/2	CHA 45/2	CHA 50/2	CHA 60/2	CHA 70/2	CHA 80/2
0.5	1.1	1.8	3.6	7.3	7.5	14.0	11.0

NOTE: The gearboxes are supplied without oil.

VALUE OF VISCOSITY ACCORDING TO TYPE OF LOAD AND TEMPERATURE				
Type of loads	CHA 0°C - 20°C		CHA 20°C - 40°C	
	Mineral Oil ISO VG	Synthetic Oil ISO VG	Mineral Oil ISO VG	Synthetic Oil ISO VG
Uniform load	150	150	220	220
Medium load	150	150	320	220
Heavy load	200	200	460	320

For choosing suitable oil, you must consider viscosity values which are specified according to type of load and ambient temperature on above table.





MOUNTING POSITION

CHA 30/1

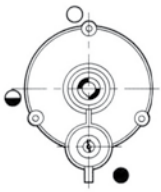

A

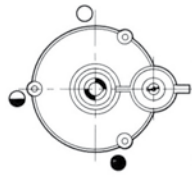

B



C

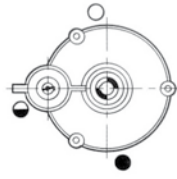

D

CHA 35/2 · CHA 50/2 · CHA 60/2 · CHA 70/2



A



B

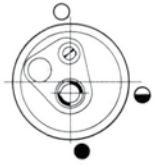

C

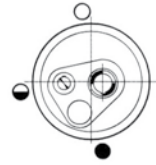

D

CHA 40/2 · CHA 45/2 · CHA 80/2

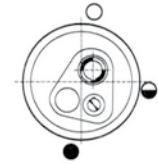

A

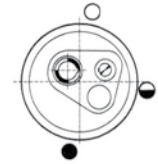

B

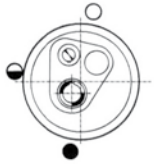

C

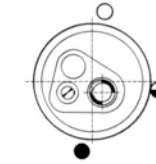

D

CHA 30/1

CHA 35/2 & CHA 80/2

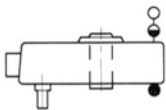

VA

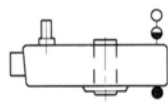

VB

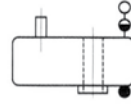

VA

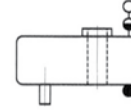

VB

- Vent plug - Filler plug
- ◐ Level plug
- Drain plug



GEAR UNIT SELECTION TABLE

		CHA 30/1/30		CHA 35/2/35			CHA 40/2/40-45			
		10	12,7	15	20	25	15	20	25	33
$n_1 = 1400 \text{ min}^{-1}$	n_2 min^{-1}	140	110	93	71	56	93	71	56	42
	Mn_2 Nm	130	130	330	360	380	715	740	760	760
	Pn_1 kW	2	1,5	3,4	2,9	2,4	7,3	5,8	4,7	3,5
	Rn_1 N	350	350	500	500	500	850	850	850	850
$n_1 = 900 \text{ min}^{-1}$	n_2 min^{-1}	90	71	60	46	36	60	46	36	27
	Mn_2 Nm	140	140	380	380	380	760	760	810	850
	Pn_1 kW	1,3	1	2,5	1,9	1,5	5	3,8	3,2	2,6
	Rn_1 N	400	400	600	600	600	950	950	950	950
$n_1 = 500 \text{ min}^{-1}$	n_2 min^{-1}	50	39	33	25	20	33	25	20	15
	Mn_2 Nm	170	170	400	400	420	850	850	900	920
	Pn_1 kW	0,9	0,7	1,4	1,1	0,9	2,9	2,4	1,9	1,5
	Rn_1 N	500	500	750	750	750	1200	1200	1200	1200

128

		CHA 45/2/45-50-55				CHA 50/2/50-55-60		CHA 60/2/60-70	CHA 70/2/70	CHA 80/2/80
		15	20	25	30	15	25	15	15	15
$n_1 = 1400 \text{ min}^{-1}$	n_2 min^{-1}	93	71	56	46	93	56	93	93	93
	Mn_2 Nm	1140	1190	1235	1235	1805	1900	3040	4180	5795
	Pn_1 kW	11,7	9,3	7,6	6,3	18,5	11,7	31,4	42,8	59,9
	Rn_1 N	1150	1150	1150	1150	1700	1700	2600	3400	4200
$n_1 = 900 \text{ min}^{-1}$	n_2 min^{-1}	60	46	36	30	60	36	60	60	60
	Mn_2 Nm	1190	1235	1300	1300	1850	1995	3135	4275	5985
	Pn_1 kW	7,9	6,2	5,1	4,2	12,3	7,9	20,9	28,5	39,9
	Rn_1 N	1300	1300	1300	1300	1900	1900	2900	3800	4700
$n_1 = 500 \text{ min}^{-1}$	n_2 min^{-1}	33	25	20	16	33	20	33	33	33
	Mn_2 Nm	1300	1350	1400	1400	2100	2300	3500	4900	6600
	Pn_1 kW	4,7	3,8	3	2,5	7,3	4,8	12,4	17,1	22,8
	Rn_1 N	1200	1200	1200	1200	2400	2400	3600	4750	5900



DIMENSION SHEET

CHA 30/1/30

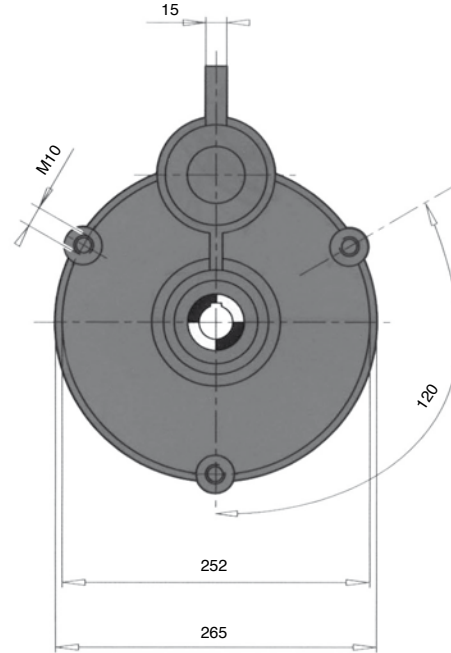
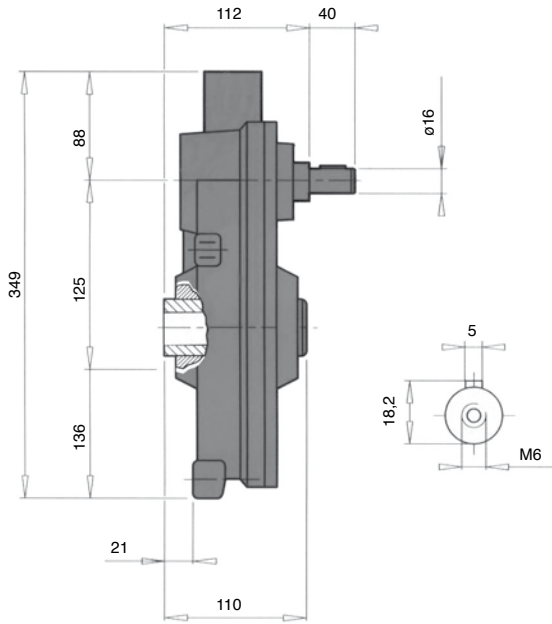

Weight Kg 19

129

OUTPUT SHAFT

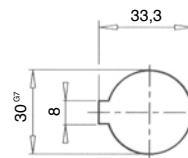
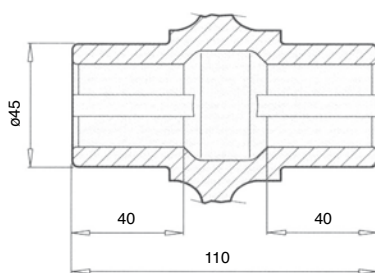

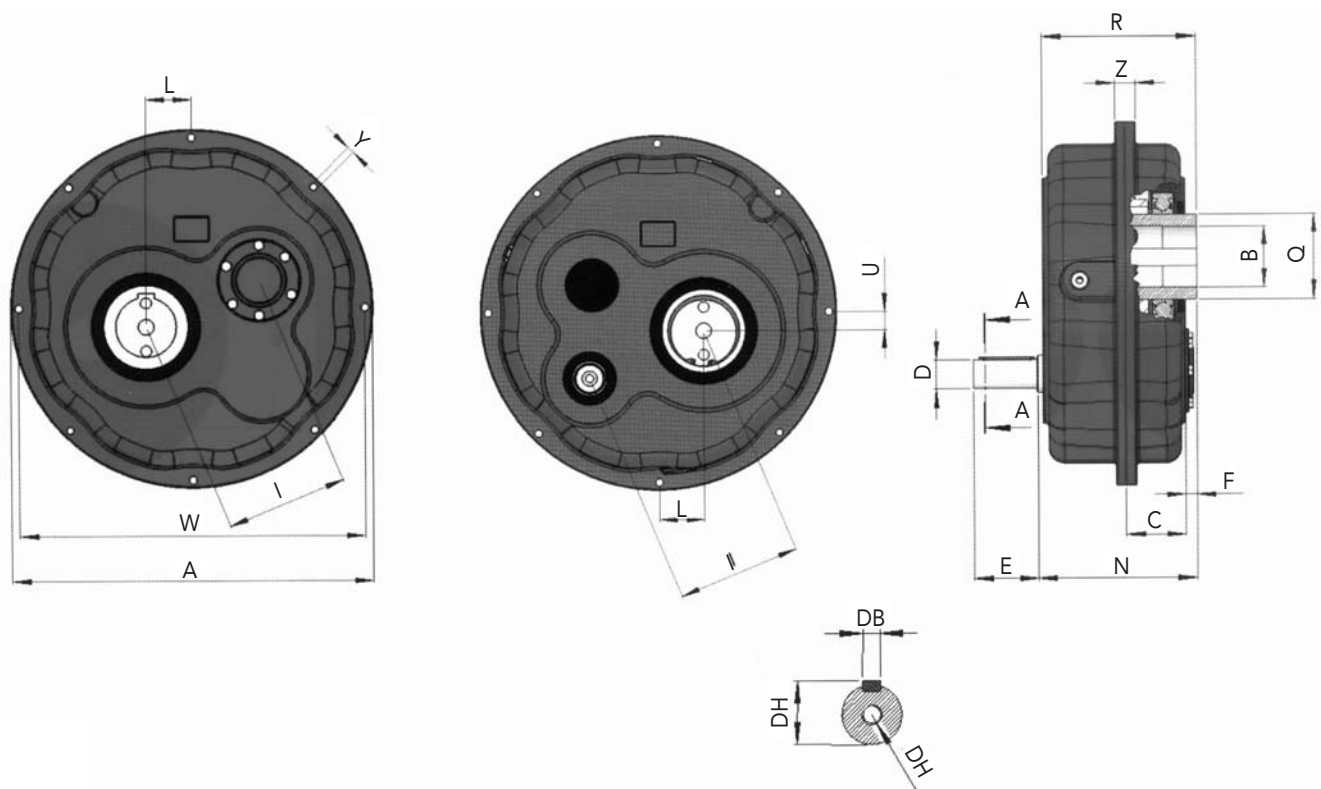

Dimensions

Type	A	B ^{G7}	C	D	DB	DH	DM	E	F	I	L	N	Q	R	U	W	Y	Z	Kg
CHA 35/2/35	265	35	44	19	6	21,5	M6	40	12	83	23	126	50	124	21	240	8,5	20,5	18
CHA 40/2/40	322	40	57	24	8	27	M8	50	11	112	30	150	60	144	22	302	8,5	20,5	28
CHA 40/2/45	322	45	57	24	8	27	M8	50	11	112	30	150	60	144	22	302	8,5	20,5	28
CHA 45/2/45	364	45	62	28	8	31	M10	60	15	123	34	164	75	162	33	344	9	20,5	38
CHA 45/2/50	364	50	62	28	8	31	M10	60	15	123	34	164	75	162	33	344	9	20,5	38
CHA 45/2/55	364	55	62	28	8	31	M10	60	15	123	34	164	75	162	33	344	9	20,5	37
CHA 50/2/50	434	50	66	38	10	42	M12	80	15	143	40	190	85	182	46	410	11	24,5	58
CHA 50/2/55	434	55	66	38	10	42	M12	80	15	143	40	190	85	182	46	410	11	24,5	58
CHA 50/2/60	434	60	66	38	10	42	M12	80	15	143	40	190	85	182	46	410	11	24,5	58
CHA 60/2/60	498	60	73	38	10	42	M12	80	15	174	47	205	100	199	48	468	13	28,5	97
CHA 60/2/70	498	70	73	38	10	42	M12	80	15	174	47	205	100	199	48	468	13	28,5	97
CHA 70/2/70	550	70	84	42	12	45	M12	110	18	188	52	228	120	223	53	520	13	28,5	121
CHA 80/2/80	597	80	94	48	14	51,5	M16	110	21	207	58	255	140	249	58	570	13	32,5	160



OUTPUT SHAFT

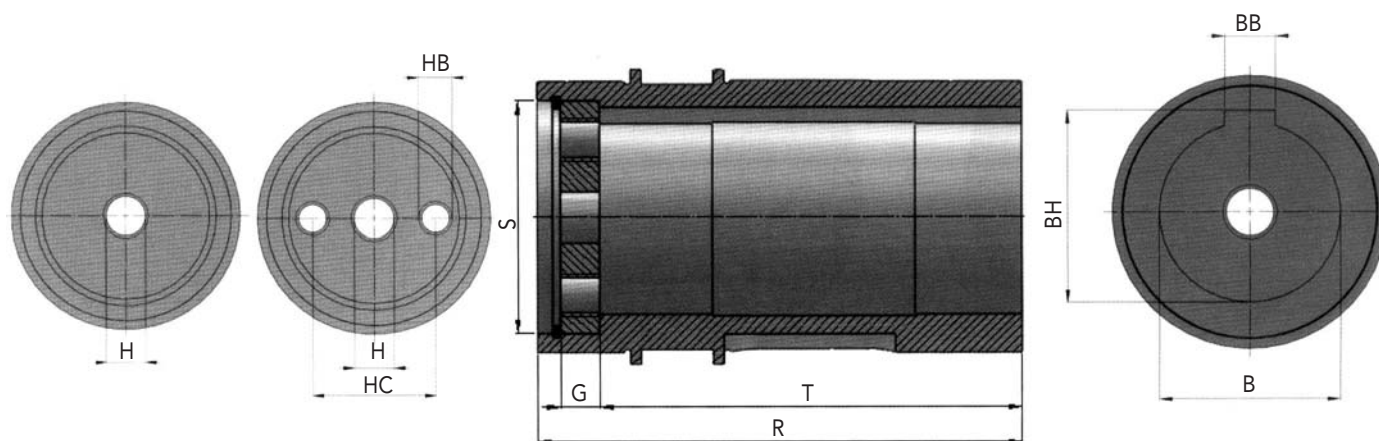

Dimensions

Type	B ^{G7}	BB	BH	G	H	HB	HC	R	S	T
CHA 30/1/30	30	8	33,3	-	-	-	-	110	-	-
CHA 35/2/35	35	10	38,3	8	M12	-	-	124	40	106
CHA 40/2/40	40	12	43,3	8	M12	-	-	144	52	124
CHA 40/2/45	45	14	47,3	8	M12	-	-	144	52	124
CHA 45/2/45	45	14	48,8	10	M16	-	-	162	62	140
CHA 45/2/50	50	14	53,8	10	M16	-	-	162	62	140
CHA 45/2/55	55	16	59,3	10	M16	-	-	162	72	140
CHA 50/2/50	50	14	53,8	10	M16	-	-	182	62	160
CHA 50/2/55	55	16	59,3	10	M16	-	-	182	72	160
CHA 50/2/60	60	18	64,4	12	17	M12	42	182	72	160
CHA 60/2/60	60	18	64,4	12	17	M12	42	199	72	175
CHA 60/2/70	70	20	74,9	12	22	M16	50	199	90	175
CHA 70/2/70	70	20	74,9	12	22	M16	50	223	90	193
CHA 80/2/80	80	22	85,4	18	22	M16	60	249	95	219



TORQUE TENSION ARM

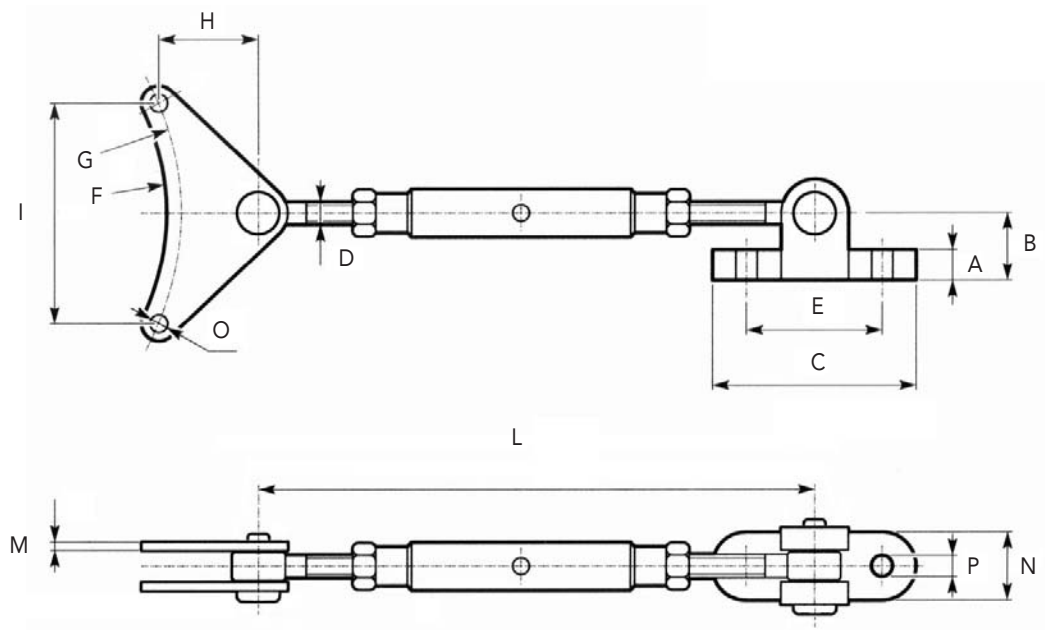

Type	A	B	C	D	E	F	G	H	I	L _{Min}	L _{Max}	M	N	O	P
CHA 35/2	10	25	75	M10	50	111	120	45	92	200	300	4	25	8,5	8,5
CHA 40/2	16	35	105	M12	70	143	151	51	115,5	210	310	4	35	8,5	10,5
CHA 45/2	16	35	105	M12	70	164	172	57	132	210	310	5	35	10,5	10,5
CHA 50/2	18	40	115	M14	75	195	205	70	157	240	360	5	40	10,5	12,5
CHA 60/2	18	40	115	M14	75	221	234	84	179	240	360	5	40	12,5	12,5
CHA 70/2	20	45	135	M16	85	247	260	100	199	260	410	6	50	12,5	14,5
CHA 80/2	20	45	135	M16	85	272	285	102	218	260	410	6	50	13	14,5



CHA DOUBLE STAGE

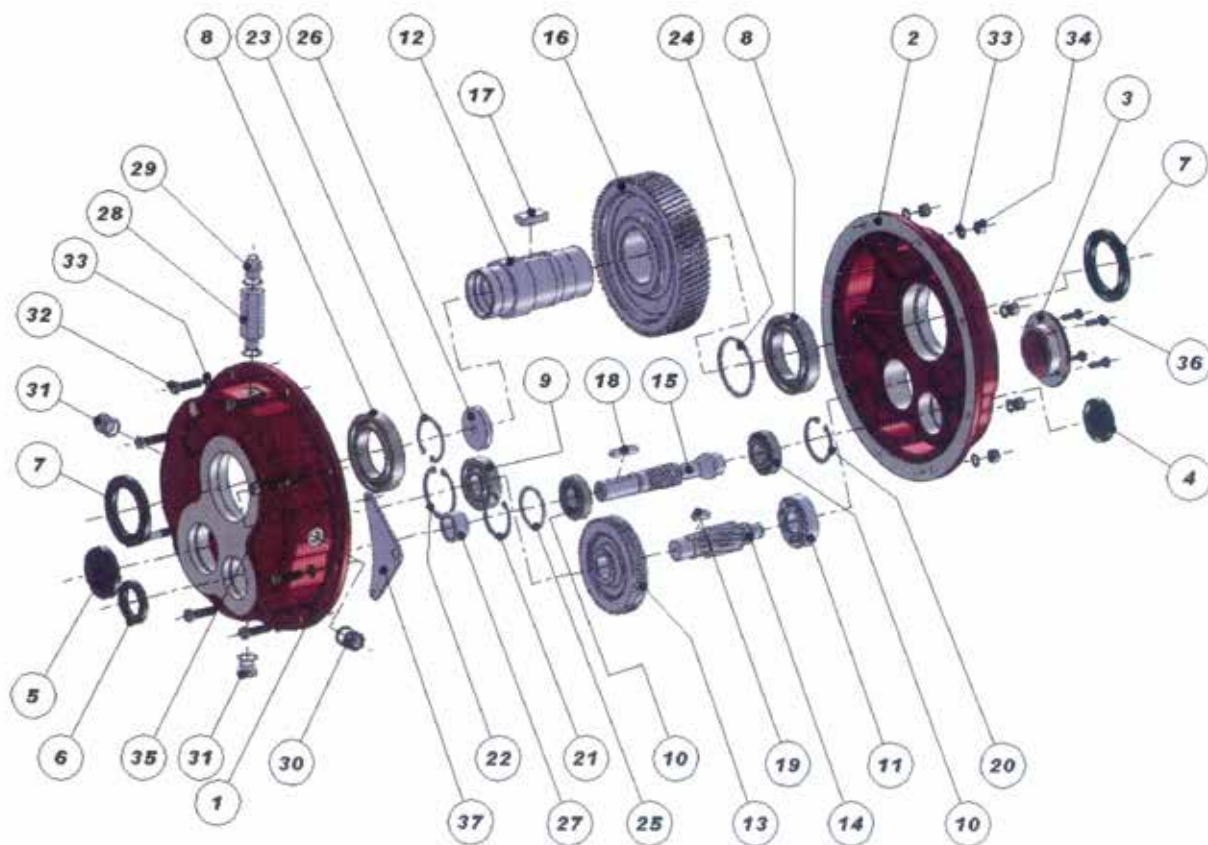

CHA DOUBLE STAGE

Part No	CHA 35/2	CHA 40/2	CHA 45/2	CHA 50/2	CHA 60/2	CHA 70/2	CHA 80/2
6	30/52/7	35/52/7	40/62/7	55/80/10	55/80/8	55/85/8	60/90/8
7	50/72/8	60/85/8	75/100/10	85/110/12	100/130/12	120/150/12	140/180/12
8	6010	6012	6015	6017	6020	6024	6028
9	6304	6305	6306	NJ 308 E	NJ 2209 E	NJ 2210 E	NJ 2211 E
10	6304	30205	30206	32208	32208	32209	32210
11	6205	NJ 305 E	NJ 306 E	NJ 308 E	NJ 2209 E	NJ 211 E	NJ 2211 E

1	CASE A	20	CIRCLIP
2	CASE B	21	CIRCLIP
3	CASE COVER	22	CIRCLIP
4	OIL COVER	23	CIRCLIP
5	OIL COVER	24	SUPPORTING DISC
6	SEAL	25	SUPPORTING DISC
7	SEAL	26	FIXING ELEMENT
8	BEARING	27	BUSH
9	BEARING	28	APPARATUS FOR EXTENSION
10	BEARING	29	VENT PLUG
11	BEARING	30	OIL LEVEL PLUG
12	OUTPUT SHAFT	31	DRAIN PLUG
13	DRIVEN GEAR	32	HEXAGONAL HEAD SCREW
14	PINION GEAR	33	WASHER
15	PINION GEAR	34	NUT
16	DRIVEN GEAR	35	STUD BOLT
17	KEY	36	HEXAGONAL SOCKET HEAD
18	KEY	37	BRACKET
19	KEY		

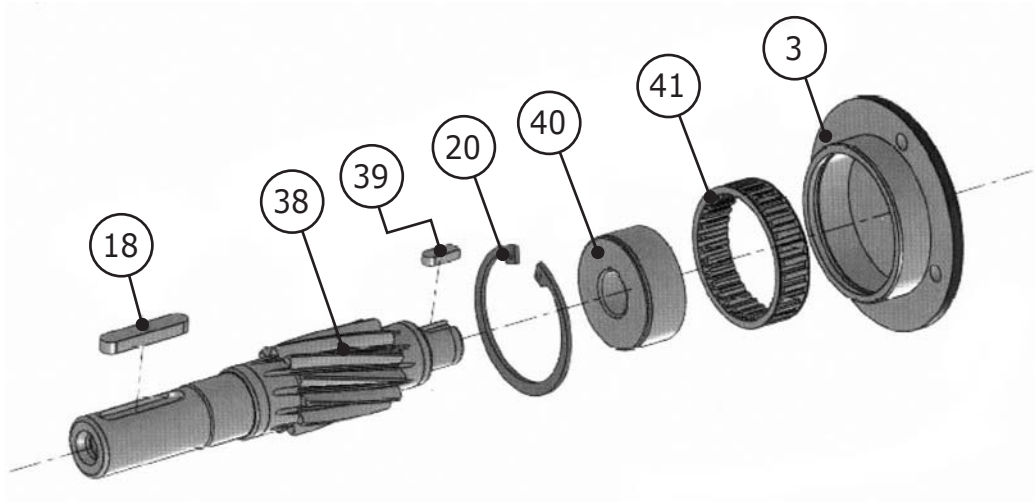

3	CASE COVER
18	KEY
20	CIRCLIP
38	PINION GEAR
39	KEY
40	BUSH
41	BACKSTOP



INSTALLATION

- The data shown on the identification name plate must correspond to the gearbox ordered.
- The oil level must correspond to the quantity foreseen for the assembly position requested (see catalogue).
- All of the other gearboxes are supplied complete with permanent synthetic oil in a quantity that is sufficient for any assembly position.
- In the event that knocks, overloading or blockage of the machine are foreseen, the client must install a limiting device, joints, overload cut-out etc.
- Coupling with pinions, joints, pulleys and other parts must be done after the parts have been cleaned and knocks should be avoided while assembling as they could damage the bearings and other internal parts.
- Check that the fixing screws for the gear and the related accessories are correctly tightened.
- Take suitable measures to protect the groups from any aggressive atmospheric agents.
- Where foreseen, protect rotating parts from any possible contact with the operators.
- If the gears are painted, protect the oil seals and the machined surfaces gearboxes.
- All of the gears are painted RAL 9022 grey.

OPERATION AND RUNNING-IN

- To obtain the best performance the gearboxes must first be run-in by gradually increasing the power in the first few hours of operation, in this phase an increase in temperature is considered normal.
- In the event of defective operation, noise, oil leakage, etc. stop the gear immediately and, when possible, remove the cause. Alternatively, send the piece to our factory to be controlled.

MAINTENANCE

- The gearboxes are supplied empty of oil and must be filled by the customer before used.

WAREHOUSE STORAGE

- If the warehouse storage will be for a long time, more than 3 months, the shafts and machined surfaces should be protected using antioxidants and the oil seals should be greased.

HANDLING

- Care must be taken not to damage the oil seals and the machined surfaces when handling the groups.

DISPOSAL OF PACKAGING

- The packaging in which our gears are delivered should be sent to specialised companies for recycling if possible.